



**UTICA
BOILERS**

**Models
MGC-8D
MGC-8DP
MGC-9D
MGC-9DP**

MGC SERIES III

**GAS-FIRED
HOT WATER BOILERS**

**INSTALLATION, OPERATION &
MAINTENANCE MANUAL**



C.S.A. Certified for
Natural gas or
Propane



Tested for 50 psi.
ASME Working
Pressure



ECR international
EST. 1928
A Family of Heating & Cooling Brands.

Manufactured by:
ECR International, Inc.
2201 Dwyer Avenue, Utica NY 13501
web site: www.ecrinternational.com

P/N 240011125, Rev. A [06/2015]

1 - DIMENSIONS

Figure 1 - Dimensions

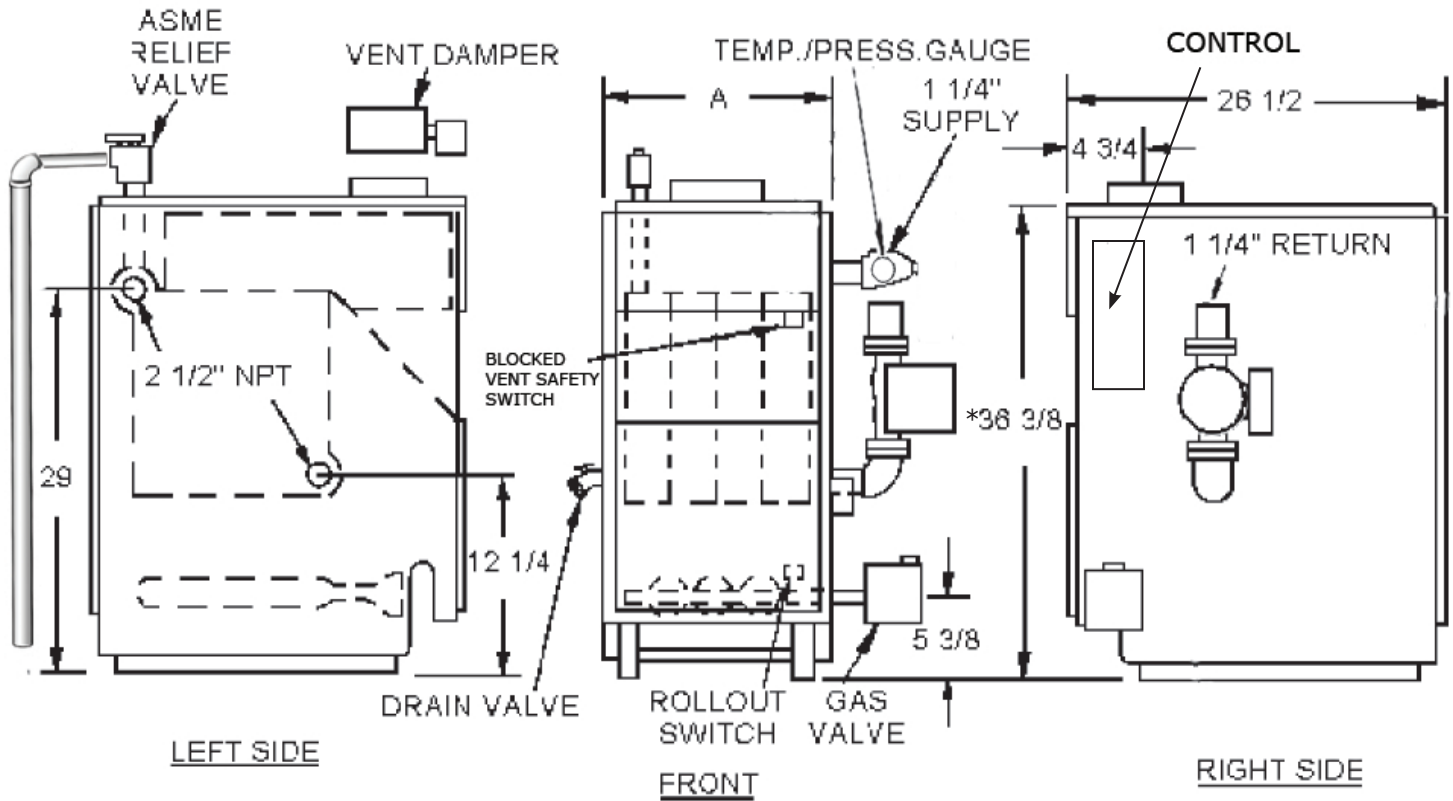

* Minimum acceptable height for Low Water Cutoff probe.

Table 1 - Dimensions		
BOILER MODEL NUMBER	DIMENSIONS (INCH.)	
	FLUE DIAMETER	"A" WIDTH
MGC-8	7	27½
MGC-9	7	30¾
Add 5½" to height for vent Damper.		

2 - BOILER RATINGS AND CAPACITIES

 Table 2 - Ratings and Capacities							
BOILER MODEL NUMBER ⁽¹⁾	† NATURAL GAS			† PROPANE GAS			AFUE
	Input ⁽³⁾ Mbh	⁽¹⁾ Heating Capacity ⁽³⁾ Mbh	⁽²⁾ NET AHRI RATING Water, ⁽³⁾ Mbh	INPUT ⁽³⁾ MBH	HEATING CAPACITY ⁽³⁾ MBH	NET AHRI RATING	INTERMITTENT IGNITION WITH VENT DAMPER
MGC-8	262.5	220	191	245	206	179	83.9
MGC-9	299	251	218	280	235	204	83.7

† Input rating for sea level to 2,000 ft. (610m) above sea level. Over 2000 ft (610m) above sea level.

Reduce input rate 4% for every 1000 ft (304m) above sea level.

+ Heating Capacity based on D.O.E. (Department of Energy) test procedure.

⁽¹⁾ Add model number suffice 'P' for Propane.

⁽²⁾ Net AHRI Water rating shown based on piping and pickup allowance of 1.15. Consult manufacturer before selecting boiler for installations having unusual piping and pickup requirements, such as intermittent system operation, extensive piping systems, etc.

⁽³⁾ MBH = 1,000 Btuh = British Thermal Unit Per Hour

Ratings marked "Net AHRI Ratings" indicate amount of remaining heat input used to heat radiation or terminal units. Net AHRI Ratings shown are based on allowance of 1.15 in accordance with factors shown on AHRI Standard as published by The Hydronics Institute.

- Selection of boiler size should be based upon "Net AHRI Rating" being equal to or greater than calculated heat loss of the building.

- Consult manufacturer before selecting boiler for installations having unusual piping and pickup requirements.

BOILERS FOR USE AT HIGH ALTITUDE

Boiler is factory equipped for use at altitudes of 0-2,000 feet above sea level.

For use at altitudes above 2,000 feet above sea level, input ratings are reduced by change in main burner orifice size.

For altitudes above 2,000 feet above sea level, input ratings should be reduced at rate of 4% for each 1,000 feet above sea level. Consult National Fuel Gas Code, ANSI Z223.1/NFPA 54 or manufacturer for correct orifice sizing information.

3 - TABLE OF CONTENTS

1 - Dimensions.....	2
2 - Ratings And Capacities	3
3 - Table of Contents.....	4
4 - Installation Procedure	5
5 - Ventilation & Combustion Air	6
6 - Connecting Supply And Return Piping	7
7 - Chimney And Vent Pipe Connection	11
8 - Vent Damper Operation	14
9 - Gas Supply Piping.....	15
10 - Electrical Wiring.....	15
11 - Wiring Diagrams	16
12 - General Instructions.....	19
13 - Lighting Instructions	20
14 - Operating Your Boiler	21
15 - Maintaining Your Boiler	23
16 - Service Hints.....	24
17 - Equipment And Optional Accessories	25
Appendix A - Control Module	27

SAFETY SYMBOLS & WARNINGS

The following defined symbols are used throughout this manual to notify the reader of potential hazards of varying risk levels.

DANGER

Indicates a hazardous situation which, if not avoided, WILL result in death or serious injury

WARNING

Indicates a hazardous situation which, if not avoided, could result in death or serious injury.

CAUTION

Indicates a hazardous situation which, if not avoided, could result in minor or moderate injury.

NOTICE

Used to address practices not related to personal injury.

**KEEP THIS MANUAL NEAR BOILER
RETAIN FOR FUTURE REFERENCE**

**IMPORTANT: Read the following instructions
COMPLETELY before installing!!**

WARNING

Fire, explosion, asphyxiation and electrical shock hazard. Improper installation could result in death or serious injury. Read this manual and understand all requirements before beginning installation.

WARNING

Keep boiler area clear and free from combustible materials, gasoline and other flammable vapors and liquids.

DO NOT obstruct air openings to the boiler room. Modification, substitution or elimination of factory equipped, supplied or specified components may result in personal injury or loss of life.

TO THE OWNER - Installation and service of this boiler must be performed by a qualified installer.

TO THE INSTALLER - Leave all instructions with boiler for future reference.

When this product is installed in the Commonwealth of Massachusetts the installation must be performed by a Licensed Plumber or Licensed Gas Fitter.

4 - INSTALLATION PROCEDURE

⚠ WARNING

Improper installation, adjustment, alteration, service or maintenance could result in death or serious injury.

1. Installation must conform to the requirements of the authority having jurisdiction or, in the absence of such requirements, to the National Fuel Gas Code, ANSI Z223.1/NFPA 54, and/or Natural Gas and Propane Installation Code, CAN/CSA B149.1.
2. Where required by the authority having jurisdiction, the installation must conform to the Standard for Controls and Safety Devices for Automatically fired Boilers, ANSI/ASME CSD-1.
3. Boiler series is classified as a Category I. Vent installation shall be in accordance with "Venting of Equipment," of the National Fuel Gas Code, ANSI Z223.1/NFPA 54, or "Venting Systems and Air Supply for Appliances," of the Natural Gas and Propane Installation Code, CAN/CSA B149.1, or applicable provisions of the local building codes.
4. Boiler has met safe lighting and other performance criteria with the gas manifold and control assembly on the boiler per the latest revision of ANSI Z21.13/CGA 4.9.
5. Install boiler such that gas ignition system components are protected from water (dripping, spraying, rain, etc.) during appliance operation and service, (circulator replacement, condensate trap, control replacement, etc.).
6. Locate boiler on level, solid base as near chimney as possible and centrally located with respect to heat distribution system as practical.
7. Allow 24 inches (610mm) at front and right side for servicing and cleaning.
8. When installed in utility room, door should be wide enough to allow largest boiler part to enter, or to permit replacement of another appliance such as water heater.

⚠ WARNING

Fire hazard. Do not install boiler on combustible flooring or carpeting. Failure to follow these instructions could result in death or serious injury.

1. **FOR INSTALLATION ON NON-COMBUSTIBLE FLOORS ONLY** - For installation on combustible flooring special base must be used. (See Replacement Parts Section.) **Boiler shall not be installed on carpeting.**

Table 3 - MINIMUM CLEARANCE DIMENSIONS

	Inches	(mm)
Top	6"	(152mm)
Rear	6"	(152mm)
Control Side	7"	(178mm)
Opposite Side	6"	(152mm)
Front	18"	(457mm)
Flue/Vent Connector	6"	(152mm)
Near Boiler Piping	1/2"	(13mm)

NOTE: Greater clearances for access should supersede fire protection clearances.

* Definition of Alcove is three sided space with no wall in front of boiler. ANSI standard for alcove is 18 inches from front of appliance to leading edge of side walls as shown below.

Minimum Clearances to Combustible Construction (as seen from above)

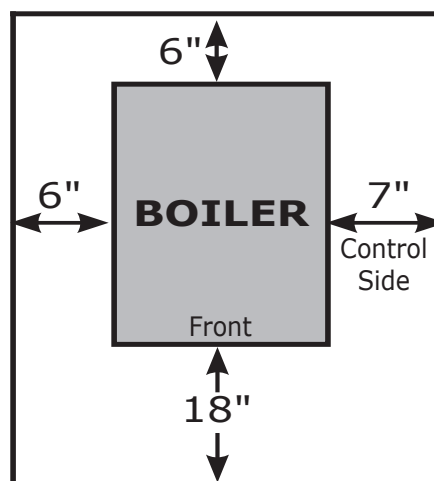

5 - VENTILATION & COMBUSTION AIR

Provide combustion air and ventilation air in accordance with the section "Air for Combustion and Ventilation," of the National Fuel Gas Code, ANSI Z223.1/NFPA 54, or Sections 8.2, 8.3 or 8.4 of Natural Gas and Propane Installation Code, CAN/CSA B149.1, or applicable provisions of local building codes.

Provide make-up air where exhaust fans, clothes dryers, and kitchen ventilation equipment interfere with proper operation.

National Fuel Gas Code recognizes several methods of obtaining adequate ventilation and combustion air. Requirements of the authority having jurisdiction may override these methods.

- Engineered Installations. Must be approved by authority having jurisdiction.
- Mechanical Air Supply. Provide minimum of 0.35 cfm per Mbh for all appliances located within space. Additional requirements where exhaust fans installed. Interlock each appliance to mechanical air supply system to prevent main burner operation when mechanical air supply system not operating.
- All Indoor Air. Calculate minimum allowable room volume for all appliances in space. Use a different method if minimum volume not available.
 - A. Standard Method. Cannot be used if known air infiltration rate is less than 0.40 air changes per hour. See Table 4 for space with boiler only. Use equation for multiple appliances.

$$\text{Volume} \geq 50 \text{ ft}^3 \times \text{Total Input [Mbh]}$$
 - B. Known Air Infiltration Rate. See Table 4 for space with boiler only. Use equation for multiple appliances. Do not use an air infiltration rate (ACH) greater than 0.60.

$$\text{Volume} \geq 21 \text{ ft}^3/\text{ACH} \times \text{Total Input [Mbh]}$$
 - C. Refer to National Fuel Gas Code for opening requirements between connected indoor spaces.

- All Outdoor Air. Provide permanent opening(s) communicating directly or by ducts with outdoors.
 - A. Two Permanent Opening Method. Provide opening commencing within 12 inches of top and second opening commencing within 12 inches of bottom of enclosure.
 - Direct communication with outdoors or communicating through vertical ducts. Provide minimum free area of 1 in² per 4 Mbh of total input rating of all appliances in enclosure.
 - Communicating through horizontal ducts. Provide minimum free area of 1 in² per 2 Mbh of total input rating of all appliances in enclosure.
 - B. One Permanent Opening Method. Provide opening commencing within 12 inches of top of enclosure. Provide minimum clearance of 1 inch on sides/back and 6 inches on front of boiler (does not supersede clearance to combustible materials).
- Refer to National Fuel Gas Code for additional requirements for louvers, grilles, screens and air ducts.
- Combination Indoor and Outdoor Air. Refer to National Fuel Gas Code for application information.

Canada

National Gas and Propane Installation Code Requires providing air supply in accordance with:

- Section 8.2 and 8.3 when combination of appliances has a total input of up to and including 400 Mbh (120 kW).
- Section 8.4 when combination of appliances has total input exceeding 400 Mbh (120 kW).
- Refer to Natural Gas and Propane Installation Code for specific air supply requirements for enclosure or structure where boiler is installed, including air supply openings and ducts.

		Room Cubic Feet Volume					
Input Mbh	Standard Method	Known Air Infiltration Rate Method (Air Changes Per Hour)					
		0.1	0.2	0.3	0.4	0.5	0.6
262.5	13125	55125	27563	18375	13781	11025	9188
299	14950	62790	31395	20930	15698	12558	10465

* Table values based on boiler only. Add volume for any additional appliances.

⚠ WARNING

Burn and scald hazard. Safety relief valve could discharge steam or hot water during operation. Install discharge piping per these instructions.

1. Refer to local codes and appropriate ASME Boiler and Pressure Vessel Code for additional installation requirements. Install safety relief valve using pipe fittings provided with boiler. See Figure 2
2. Install safety relief valve with spindle in vertical position.
3. Do not install shutoff valve between boiler and safety relief valve.
4. Install discharge piping from safety relief valve. See Figure 2.
 - Use $\frac{3}{4}$ " or larger pipe.
 - Use pipe suitable for temperatures of 375°F (191°C) or greater.
 - Individual boiler discharge piping shall be independent of other discharge piping.
 - Size and arrange discharge piping to avoid reducing safety relief valve relieving capacity below minimum relief valve capacity stated on rating plate.
 - Run pipe as short and straight as possible to location protecting user from scalding and properly drain piping.
 - Install union, if used, close to safety relief valve outlet.
 - Install elbow(s), if used, close to safety relief valve outlet and downstream of union (if used).
 - Terminate pipe with plain end (not threaded).

Figure 2 - Safety Relief Valve

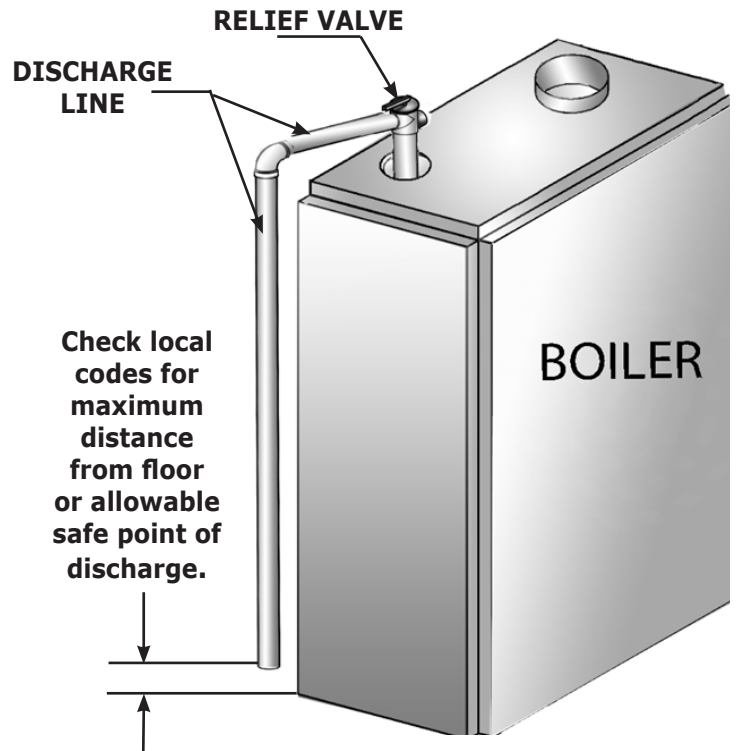

6 - CONNECTING SUPPLY AND RETURN PIPING

⚠ WARNING

Burn and scald hazard. Safety relief valve could discharge steam or hot water during operation. Install discharge piping per these instructions.

1. Boiler is shipped assembled. Install discharge piping from safety relief valve. See Warning, Page 7.
2. Install temperature pressure gauge.
 - Apply pipe sealant to threads on shaft of gauge.
 - Thread gauge into supply water tee. See Figure 3.

NOTICE

DO NOT TIGHTEN GAUGE BY HAND!! Gauge should be tightened using crescent wrench or 9/16" open end wrench. See Figure 3.

3. Connect supply and return lines to boiler. Connections may require additional fittings and parts, as shown on diagrams.

Figure 3 - Temperature Pressure Gauge

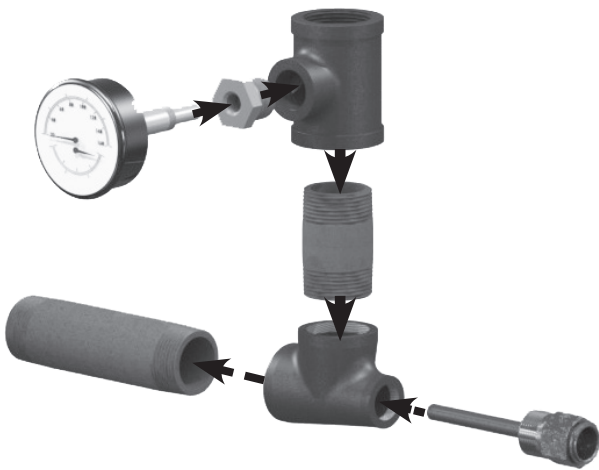

Verify clean water supply is available to water inlet valve. Install sand strainer when water supply is from a well or pump.

Install hot water boiler above radiation level or as required by Authority having jurisdiction install low water cutoff device at time of installation. See Figure 1 for minimum probe height. Use kit #550002998. follow instruction enclosed with kit. With other LWCO's use their manufacturer specific instructions.

Periodic inspection is necessary, as is flushing of float type devices, per manufacturers specific instruction.

FOR USE WITH COOLING UNITS

- A. Boiler used in connection with refrigeration system, must be installed so that chilled medium is piped in parallel with heating boiler. Appropriate valves must be used to prevent chilled medium from entering heating boiler. See Figure 5 page 9.
- B. Boiler connected to heating coils located in air handling units where they may be exposed to refrigerated air circulation, piping system shall be equipped with flow control valves or other automatic means to prevent gravity circulation of boiler water during cooling cycle.

LOW WATER TEMPERATURE AND LARGE WATER CONTENT SYSTEM (See Figures 6 and 7, Page 10.)

Significant condensation may form in boiler and/or venting system if boiler is operated for long period of time with return temperatures of less than 120° F.

Condensate is corrosive and can cause severe damage to boiler and venting system. Minimum design return water temperature to prevent condensation in boiler and venting is 120°F. Minimum high limit setting is 140°F.

1. Boiler used in heating system where design water temperatures below 140°F are desired (e.g. radiant floor heating), 4-way mixing valve or suitable alternative is required to prevent low temperature return water from entering boiler. Follow mixing valve manufacturer's instructions.
2. Boiler connected to system having large water content (such as former gravity system), install system bypass. See Figures 6 and 7, page 10.
3. If boiler water reset control is used to operate boiler, minimum reset supply water temperature setpoint must be at least 140°F, unless mixing valve is used as in (1) above.

Figure 4 - Typical Hot Water Piping

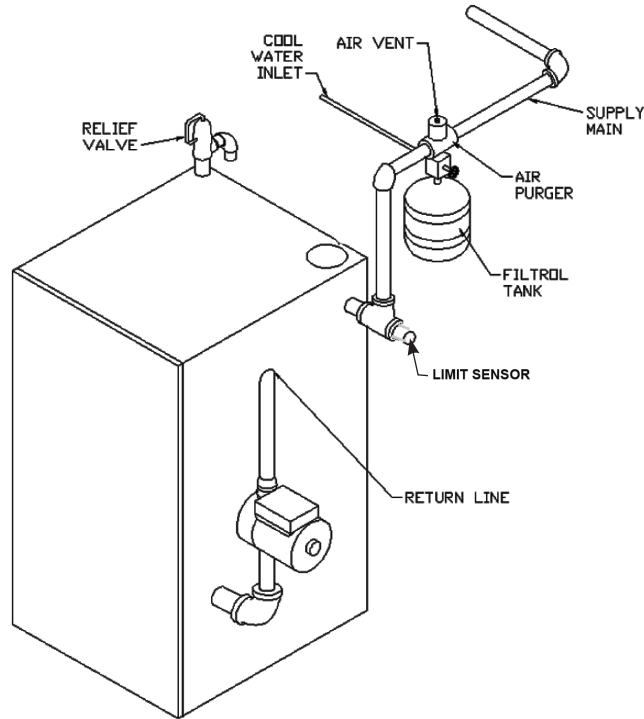
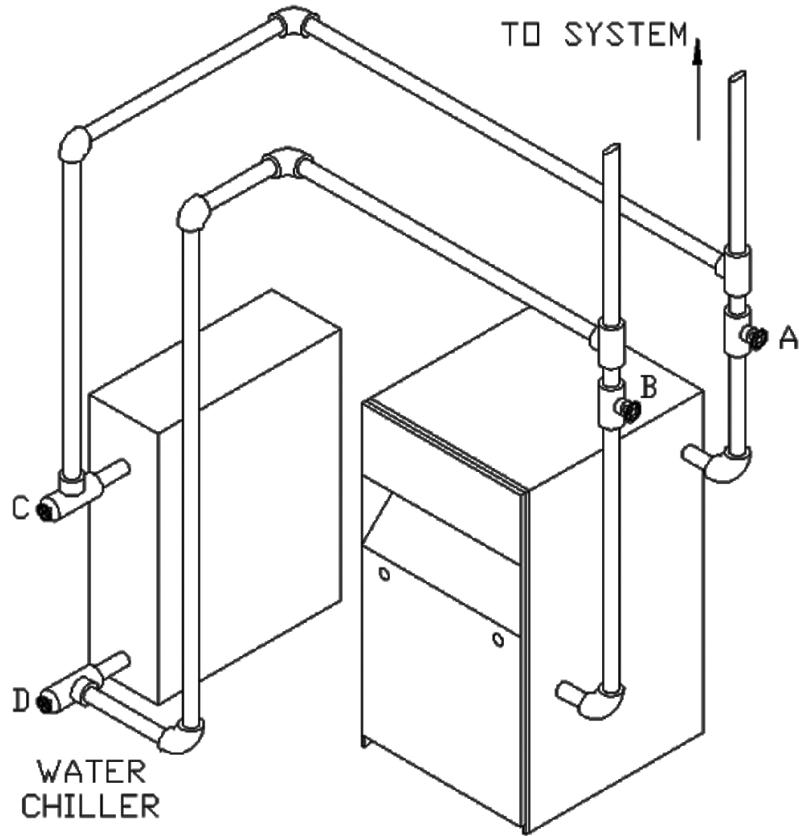

Figure 5 - Chilled Water Piping

VALVES A & B
OPEN FOR HEATING;
CLOSE FOR COOLING

VALVES C & D
CLOSE FOR HEATING;
OPEN FOR COOLING



6 - CONNECTING SUPPLY AND RETURN PIPING

Bypass Piping Required For High Mass (Large Water Content) Systems

Figure 6 - BYPASS PIPING - CIRCULATOR ON SUPPLY

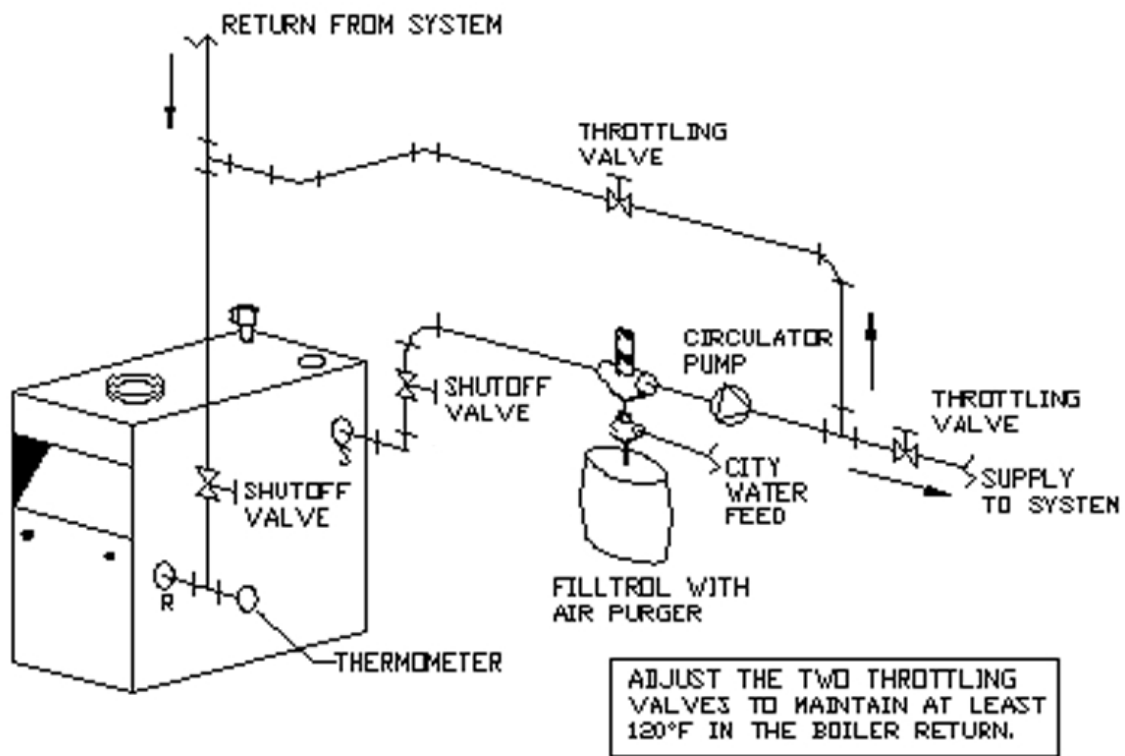
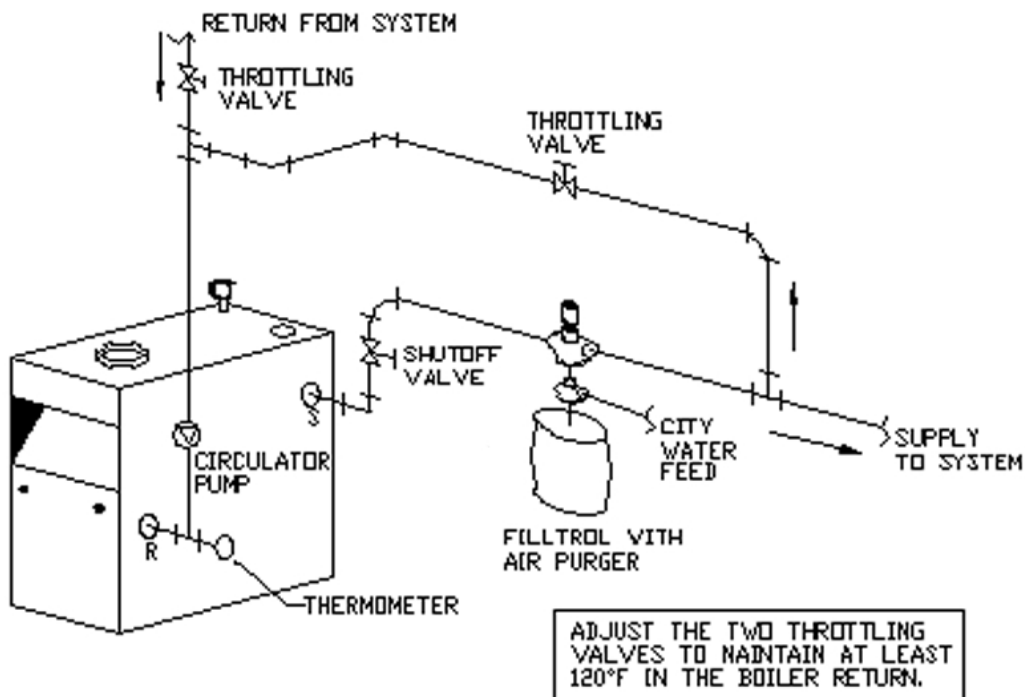

Figure 7 - BYPASS PIPING - CIRCULATOR ON RETURN



WARNING

Boiler and venting installations shall be performed by a qualified expert and in accordance with the appropriate manual. Installing or venting boiler or other gas appliance with improper methods or materials may result in serious injury or death due to fire or to asphyxiation from poisonous gases such as carbon monoxide which is odorless and invisible.

Boilers connecting to gas vents or chimneys, vent installations shall be in accordance with "Venting of Equipment", of the National Fuel Gas Code, ANSI Z223.1/NFPA 54 or "Venting Systems and Air Supply for Appliances," of the Natural Gas and Propane Installation Code, CAN/CSA B149.1, or applicable provisions of the local building codes.

Check Your Chimney

It must be clean, right size, properly constructed and in good condition.

Chimney Sizing

Chimney sizing, and vent installation must be in accordance with The National Fuel Gas Code, ANSI Z223.1/NFPA 54 or CAN/CSA B149.1, or applicable provisions of local building codes.

This is a high efficiency boiler with low stack temperature. Following recommendations are in addition to requirements of the National Fuel Gas Code.

1. Type B double wall vent pipe is recommended for vent connector. Single wall vent connectors should not be used unless following conditions are true:
 - a) Except for basement, boiler is not installed in unheated space.
 - b) Total horizontal portion of vent connector, not including elbows is less than 5 feet in length.
2. Outside chimneys (i.e. chimneys exposed to outdoors below roof line) should not be used unless they are:
 - a) enclosed in a chase, or
 - b) lined with type B vent pipe, or listed flexible vent liner, or other certified chimney lining system.
3. Where possible it is recommended to common vent boiler and water heater.
4. For multiple boiler installations, consult boiler manufacturer for venting recommendations.

Connecting The Vent Damper And Vent Connector

Refer to Figure 1, page 2 for size and location of vent (flue opening).

NOTICE

Damper blade on furnished vent damper has 1/2 square inch hole (approximately 3/4" diameter). Boilers equipped with intermittent ignition, hole should be plugged by using plug supplied with vent damper.

1. Position furnished vent damper on top of flue outlet collar. Fasten damper securely to flue outlet collar with sheet metal screws. Verify damper blade has clearance to operate inside of diverter. Do not modify either draft diverter or vent damper during installation.

As An Option

Damper may be installed in horizontal or vertical position, closer to flue outlet collar preferred. See Figures 8, 9 and 10 and enclosed vent damper instructions.

2. Install vent damper to service only single boiler for which it is intended. Damper position indicator shall be in visible location following installation. Locate damper so it is accessible for servicing. See Figure 9.
3. Damper must be in the open position when appliance main burners are operating.
4. Boiler is equipped with factory wired harness that plugs into vent damper.
5. Slope pipe up from boiler to chimney not less than 1/4" per foot.
6. Run pipe as directly as possible with as few elbows as possible.
7. Do not connect to fireplace flue.
8. End of vent pipe must be flush with inside face of chimney flue. Use a sealed-in thimble for chimney connection.

Fasten sections of vent pipe with sheet metal screws to make piping rigid. Support horizontal portions of vent system to prevent sagging. Use stovepipe wires every 5' to support pipe from above. Use double wall vent pipe if vent pipe must go through crawl space. Where vent pipe passes through combustible wall or partition, use ventilated metal thimble. Thimble should be 4 inches larger in diameter than vent pipe.

Minimum Vent Pipe Clearance

7 - CHIMNEY AND VENT PIPE CONNECTION

WARNING

Boiler and venting installations shall be performed by a qualified expert and in accordance with the appropriate manual. Installing or venting boiler or other gas appliance with improper methods or materials may result in serious injury or death due to fire or to asphyxiation from poisonous gases such as carbon monoxide which is odorless and invisible.

WARNING

Do not connect boiler to any portion of mechanical draft system operating under positive pressure.

Wood and other combustible materials must not be closer than 6" from any surface of single wall metal vent pipe. Listed Type B vent pipe or other listed venting systems shall be installed in accordance with their listing.

Removing Existing Boiler From Common Venting System

When an existing boiler is removed from common venting system, common venting system is likely to be too large for proper venting of appliances remaining connected to it.

At time of removal of existing boiler, following steps shall be followed with each appliance remaining connected to the common venting system placed in operation, while other appliances remaining connected to common venting system are not in operation.

1. Seal any unused openings in the common venting system.
2. Visually inspect the venting system for proper size and horizontal pitch and determine there is no blockage or restriction, leakage, corrosion and other deficiencies which could cause an unsafe condition.
3. Insofar as is practical, close all building doors and windows and all doors between the space in which the appliances remaining connected to the common venting system are located and other spaces of the building. Turn on clothes dryers and any appliance not connected to the common venting system. Turn on any exhaust fans, such as range hoods and bathroom exhausts, so they will operate at maximum speed. Do not operate a summer exhaust fan. Close fireplace dampers.
4. Place in operation the appliance being inspected. Follow the lighting instructions. Adjust thermostat so appliance will operate continuously.
5. Test for spillage at the draft hood relief opening after 5 minutes of main burner operation. Use the flame of a match or candle, or smoke from a cigarette, cigar or pipe.

6. After it has been determined that each appliance remaining connected to the common venting system properly vents when tested as outlined above, return doors, windows, exhaust fans, fireplace dampers and any other gas-burning appliance to their previous conditions of use.
7. Any improper operation of the common venting system should be corrected so the installation conforms with the National Fuel Gas Code, ANSI Z223.1/NFPA 54, and/or the Natural Gas and Propane Installation Code, CAN/CSA B149.1. When re-sizing any portion of the common venting system, the common venting system should be re-sized to approach the minimum size determined using the appropriate tables in Chapter 13 of the National Fuel Gas Code, ANSI Z223.1/NFPA 54, and/or the Natural Gas and Propane Installation Code, CAN/CSA B149.1.

Figure 8 - Vent Damper Installation

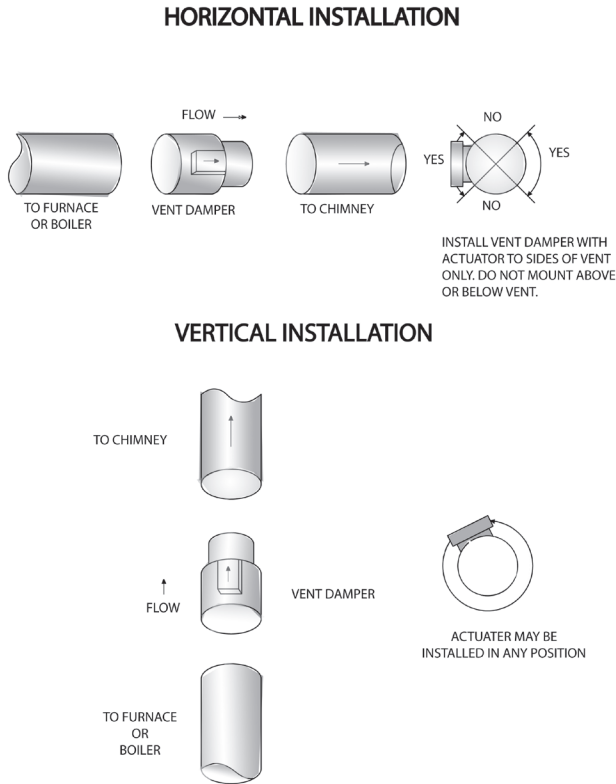
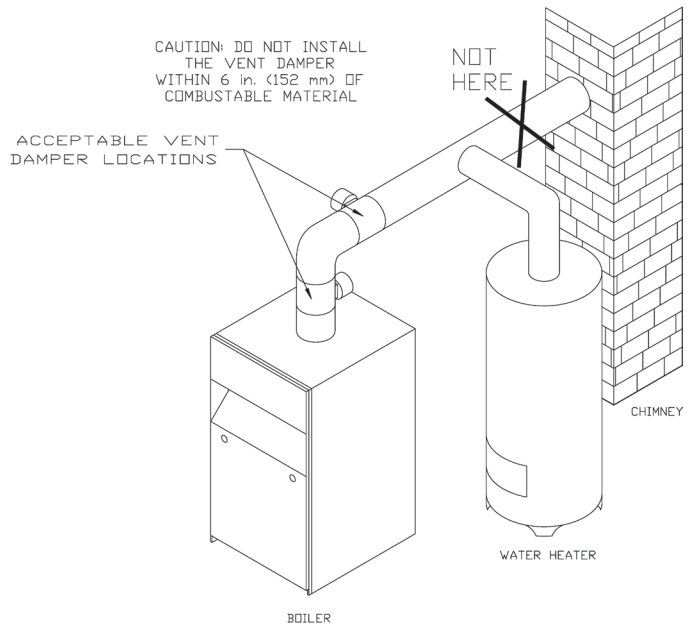

Figure 9 - Vent Damper Placement



Annually check vent damper and all flue product carrying areas of appliance, with particular attention given to deterioration from corrosion or other sources. If you see corrosion or other deterioration, contact your heating contractor for repairs. Check vent damper operation as follows:

- When boiler is off, check vent damper positions indicator points to closed position, Figure 10.
- Turn thermostat or controller up to call for heat and check vent damper indicator points to open position.
- Turn thermostat or controller down again and check damper position indicator returns to closed position.

Vent Damper Manual Operation

Vent damper may be placed in open position to permit burner operation by using "HOLD DAMPER OPEN" switch, located on damper controller. Thermostat will control burner firing as before, while damper will remain open. **DO NOT** turn damper open manually or motor damage will result. Set switch to "AUTOMATIC OPERATION" to close vent damper during burner off cycle.

For further information, and vent damper troubleshooting guide, refer to manual packaged with vent damper.

Inspect vent damper at least once a year by a qualified service technician.

Figure 10 - Vent Damper Position Indicator

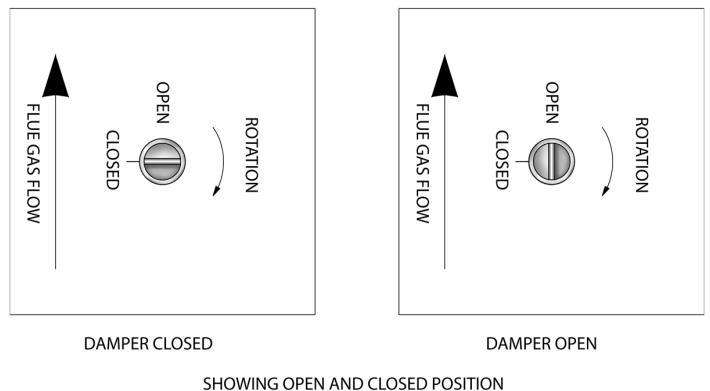

9 - GAS SUPPLY PIPING

⚠ CAUTION

WHAT TO DO IF YOU SMELL GAS

- Do not try to light any appliance.
- Do not touch any electrical switch; do not use any phone in your building.
- Immediately call your gas supplier from a neighbor's phone. Follow gas supplier's instructions.
- If you cannot reach your gas supplier, call the fire department.

CHECK GAS SUPPLY

Gas pipe to your boiler must be correct size for length of run and for total BTU per hour input of all gas utilization equipment connected to it. See Table 5 for proper size. Be sure your gas line complies with local codes and gas company requirements.

CONNECTING THE GAS PIPING See Figure 11.

Gas line enters boiler from right side.

- Use piping materials and joining methods acceptable to authority having jurisdiction. In absence of such requirements:
 - USA - National Fuel gas Code, ANSI Z223.1/NFPA 54
 - Canada - Natural Gas and Propane Installation Code, CAN/CSA B149.1
- Use pipe joint compound suitable for LP gas on male threads only.
- Use ground joint unions.
- Install sediment trap upstream of gas controls.
- Use two pipe wrenches when making connection to gas valve to keep it from turning.
- Install manual shut-off valve in vertical pipe about 5 feet above floor.
- Tighten all joints securely.
- Propane gas connections should only be made by licensed propane installer.
- Two-stage regulation should be used by propane installer.
- Propane gas piping should be checked out by propane installer.

CHECKING GAS PIPING

⚠ DANGER

Fire Hazard. Do not use matches, candles, open flames, or other methods providing ignition source. Failure to comply will result in death or serious injury.
 Pressure test boiler and gas connection before placing boiler in operation.

- Pressure test over 1/2 psig (3.5 kPa). Disconnect boiler and its individual gas shutoff valve from gas supply system.
- Pressure test at 1/2 psig (3.5 kPa) or less. Isolate boiler from gas supply system by closing manual gas shutoff valve.
- Locate leakage using gas detector, noncorrosive detection fluid, or other leak detection method acceptable to authority having jurisdiction. Do not use matches, candles, open flames, or other methods providing ignition source.
- Correct leaks immediately and retest.

Table 5 - Gas Pipe Sizes

NATURAL GAS				
	Pipe Capacity - BTU Per Hour Input Includes Fittings			
Length of Pipe - FT	1/2"	3/4"	1"	1 1/4"
20	92,000	190,000	350,000	625,000
40	63,000	130,000	245,000	445,000
60	50,000	105,000	195,000	365,000
PROPANE GAS				
	Pipe Capacity - BTU Per Hour Input Includes Fittings			
Length of Pipe - FT	Copper Tubing *		Iron Pipe	
	5/8"	3/4"	1/2"	3/4"
20	131,000	216,000	189,000	393,000
40	90,000	145,000	129,000	267,000
60	72,000	121,000	103,000	217,000

* Outside diameter
 Measure length of pipe or tubing from gas meter or propane second stage regulator.

Figure 11 - Gas Piping

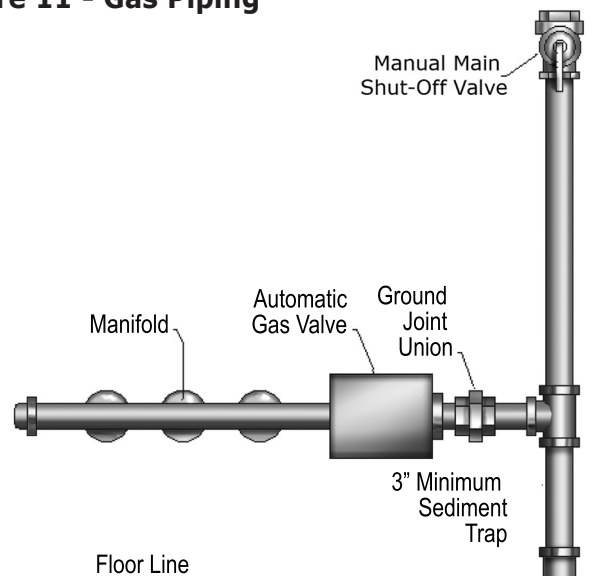

WARNING

Electrical shock hazard. Turn OFF electrical power supply at service panel before making electrical connections. Failure to do so could result in death or serious injury.

NOTICE

Label all wires prior to disconnection when servicing controls. Wiring errors can cause improper and dangerous operation. Verify proper operation after servicing.

VENT DAMPER WIRING

Boiler is equipped with factory wired harness with 4 pin molex plug, that plugs into 4 pin molex receptacle inside vent damper operator.

Vent damper must be connected for boiler to operate.

If any of the original wire as supplied with this appliance must be replaced,

It must be replaced with type 105°C thermoplastic wire or its equivalent.

Electrically bond boiler to ground in accordance with requirements of authority having jurisdiction. Refer to:

- USA- National Electrical Code, ANSI/NFPA 70.
- Canada - Canadian Electrical Code, Part I, CSA C22.1: Safety Standard for Electrical Installations.

ELECTRIC POWER SUPPLY

Run separate 120 volt circuit from separate over current protective device in electrical service entrance panel. This should be a 15 ampere circuit. Locate shut-off switch at boiler. It must be turned off during any maintenance. Connect 120 volt power supply to control leads L1 (HOT) and L2.

LWCO kit 550002998 includes wiring instructions and diagrams. If using another LWCO, refer to specific manufacturer instructions supplied by appropriate manufacturer.

Run a 14 gauge or heavier copper wire from boiler to grounded connection in service panel or properly driven and electrically grounded ground rod.

THERMOSTAT INSTALLATION

1. Thermostat should be installed on an inside wall about four feet above the floor.
2. NEVER install thermostat on outside wall.
3. Do not install a thermostat where it will be affected by drafts, hot or cold pipes, sunlight, lighting fixtures, televisions, a fireplace, or a chimney.
4. Check thermostat operation by raising and lowering thermostat setting as required to start and stop the burners.
5. Instructions for the final adjustment of the thermostat are packaged with the thermostat (adjusting heating anticipator, calibration, etc.)

Set heat anticipator at .2 amps. 24 volt thermostat connects to aquastat terminals T and TV.

Figure 12 - Integrated High Limit Electronic Ignition Control

⚠ WARNING

Modification, substitution or elimination of factory equipped, supplied or specified components may result in personal injury or loss of life.

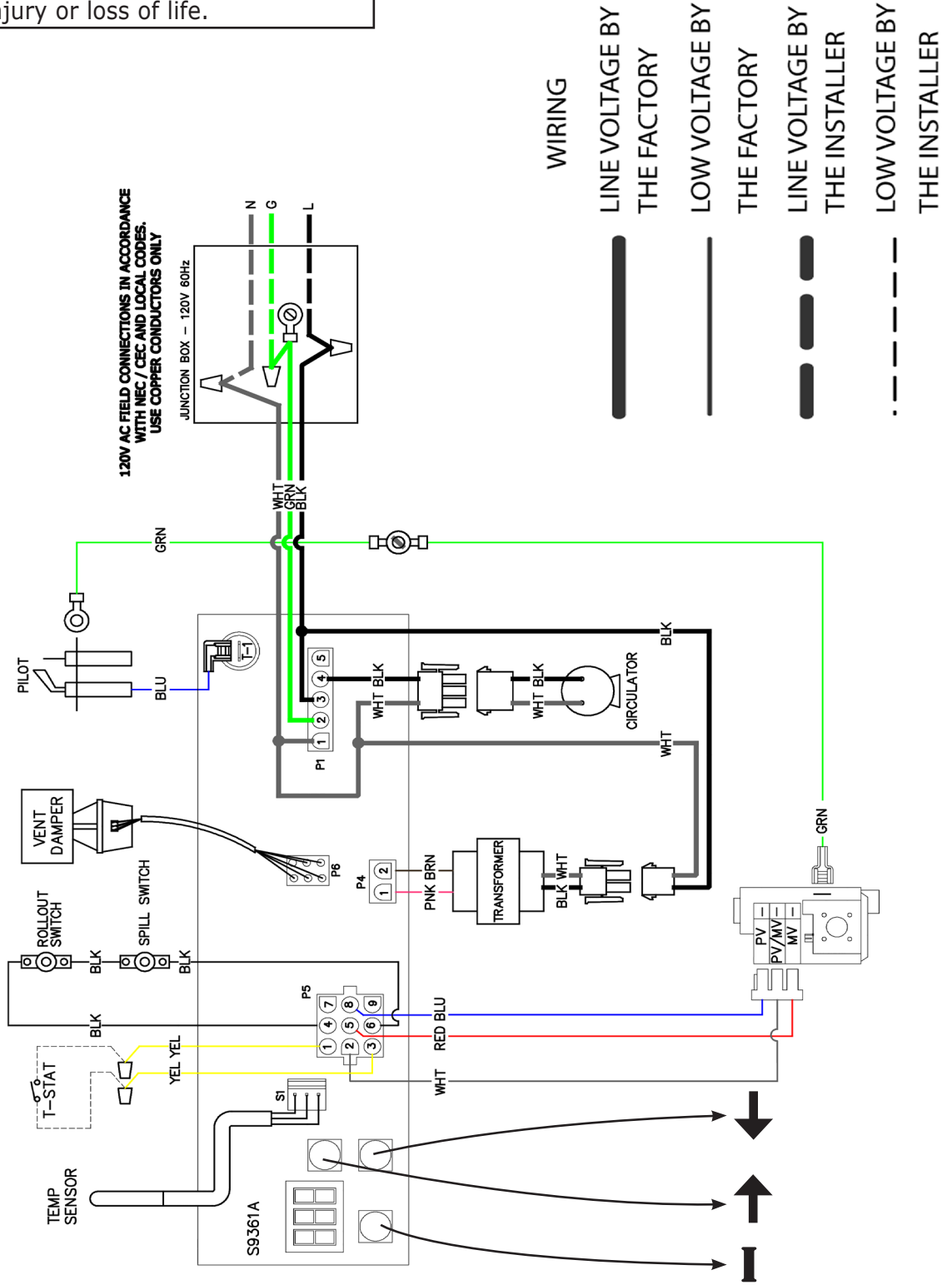
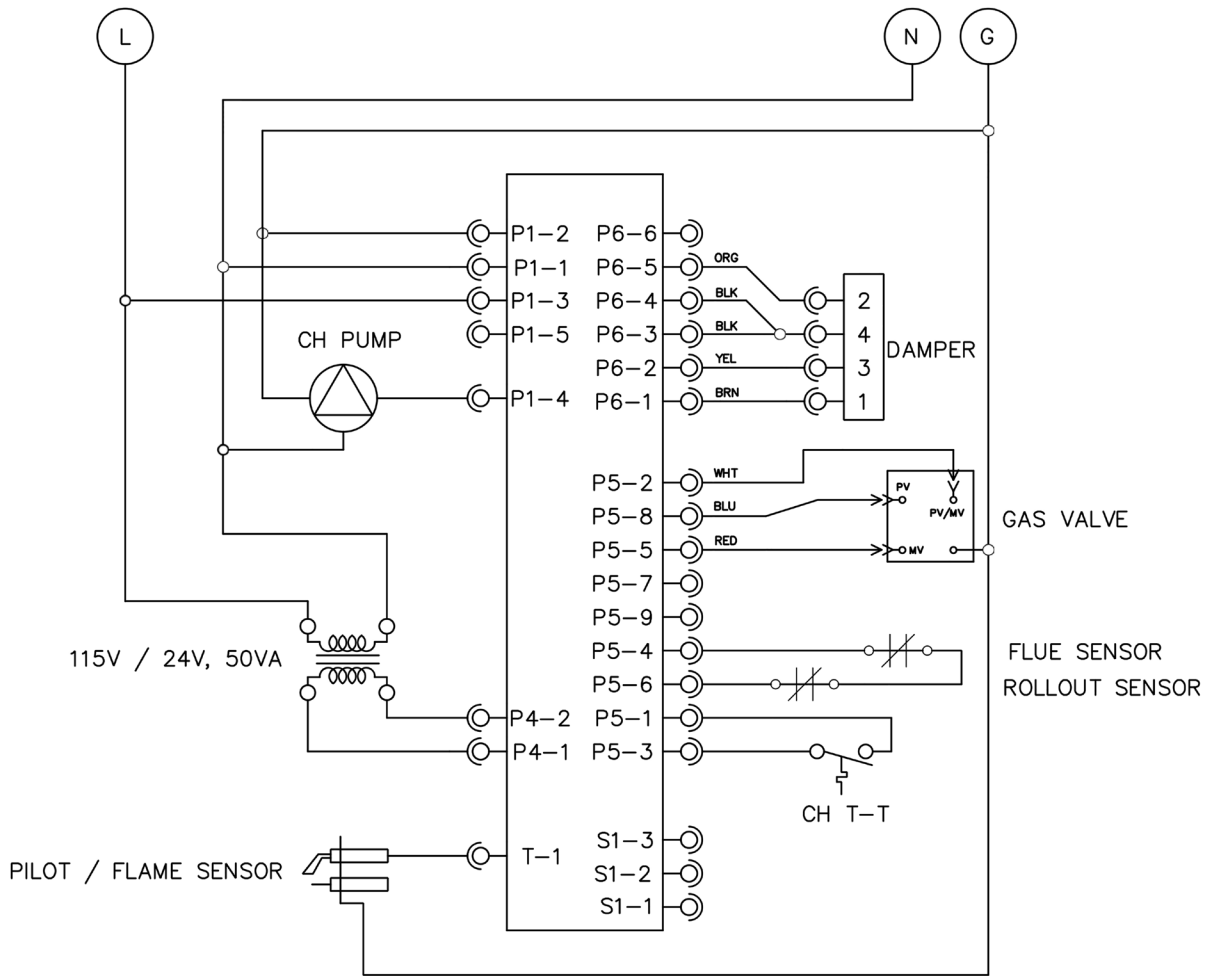

Figure 13 - Integrated High Limit Electronic Ignition Control



FILLING SYSTEM WITH WATER

- Close air vents on all radiation units. Open valves to these units.
- Verify boiler and expansion tank drain valves are closed.
- Air bleed screw on tank drain fitting should be closed.
- Open valve in line from boiler to expansion tank. Open water inlet to your boiler and leave it open. Start with lowest radiation unit. Open air vent on this unit. When all air has escaped and water starts to flow from vent, close it.
- Go to next radiation unit, and repeat this process. Repeat until you have covered every radiation units in the system (ending up at highest unit in system).
- If your units have automatic vents, manual venting is unnecessary but it will speed up the proper filling of your system.
- If your system is closed expansion tank system, you may leave it open to refill system automatically as needed.
- Check temperature pressure gauge. Not position of hand indicating pressure. This should be between 10 and 15 psi. Any lowering of this movable hand below 10 psi. Will indicate loss of water due to leakage. Automatic fill valve should compensate for this. Instructions are packaged with the valve.

NOTICE

Never run water in a hot empty boiler.

⚠ WARNING

If you do not follow these instructions exactly, a fire or explosion may result causing property damage, personal injury or loss of life.

- This appliance is equipped with an ignition device which automatically lights burner. **Do NOT try to light this burner by hand.**
- Before operating smell all around appliance area for gas. Be sure to smell next to floor because some gas is heavier than air and will settle to the floor.
- **Use only your hand to turn the gas shutoff valve.** Never use tools. If valve will not turn by hand, do not try to repair it, call a qualified service technician. Force or attempted repair may result in fire or explosion.
- **Do not use this appliance if any part has been under water.** Immediately call a qualified service technician to inspect appliance and to replace any part of control system and any gas control which has been under water.

LIGHTING PROCEDURE FOR BOILER WITH INTERMITTENT PILOT SYSTEM

For Your Safety, Read Before Operating!!

- A. This appliance is equipped with an ignition device which automatically lights the pilot. Do not try to light appliance by hand.

⚠ CAUTION

WHAT TO DO IF YOU SMELL GAS

- Do not try to light any appliance.
- Do not touch any electrical switches; do not use any phone in your building.
- Immediately call your gas supplier from a neighbor's phone. Follow the gas supplier's instructions.
- If you cannot reach your gas supplier, call the fire department.

1. STOP! Read the safety information above.
2. Set the thermostat to lowest setting.
3. Turn off all electric power to the appliance.
4. This appliance is equipped with an ignition device which automatically lights the pilot. Do **not** try to light the pilot by hand.

5. Remove lower front panel.
6. Rotate the gas control knob clockwise to "OFF".

Figure 14 - Automatic Gas Valve

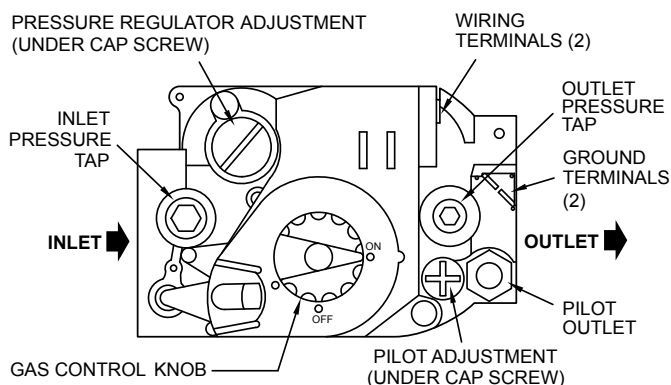

7. Wait five (5) minutes to clear out any gas. Then smell for gas, including near the floor. If you smell gas, STOP! Immediately call your gas supplier from a neighbor's phone. Follow the gas supplier's instructions. If you don't smell gas, go to next step.
8. Rotate gas control knob counterclockwise to "ON".
9. Replace lower front panel.
10. Turn on all electric power to the appliance.
11. Set thermostat to desired setting.
12. If the appliance will not operate, follow the instructions "To Turn Off Gas To Appliance" and call your service technician or gas supplier.

TO TURN OFF GAS TO APPLIANCE

1. Set the thermostat to lowest setting.
2. Turn off all electric power to the appliance if service is to be performed.
3. Push in gas control knob slightly and turn clockwise to "OFF" Do not force.

AUTOMATIC GAS VALVE

Automatic Gas Valve opens or closes according to heat requirements of thermostat and temperature limit control. It closes if pilot goes out. Each individual control must be operating correctly before any gas can pass to burners. Any one control can hold gas supply from burner regardless of demand of any other control.

SAFETY PILOT

Safety Pilot prevents flow of gas to burner if pilot goes out, or will not ignite.

GAS VALVE SAFETY SHUTDOWN TEST

Ignition system safety shutoff device must be tested after placing boiler in operation.

RELIGHT

Electric and gas shall be off for 5 minutes before relighting.

THERMOSTAT

Keep it set at desired room temperature. If windows are to be opened or heat is not needed, move thermostat pointer to lower setting.

NOTICE

In event of failure of any component, system will not operate or will go into safety lockout. System is completely self-checking. On every call for heat, each component must be functioning properly to permit operation. Safety lockout system has to be reset by turning thermostat to lowest setting for one minute, then back to normal setting.

ADJUST PILOT BURNER

Pilot flame should surround 3/8" to 1/2" of the pilot sensor. See Figure 15. If flame needs adjusting, do it as follows:

1. Remove screw cover over pilot adjusting screw.
2. Insert small screwdriver and adjust flame as needed. Turn screw counterclockwise to increase flame, clockwise to decrease.
3. Replace screw cover over pilot adjusting screw.

Figure 15 - Pilot Flame

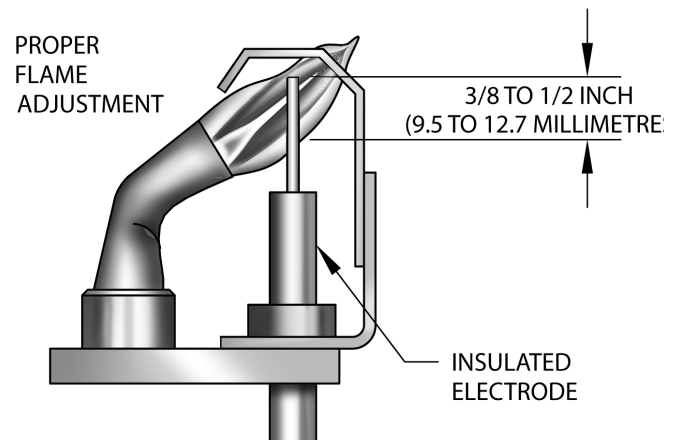

MAIN BURNER(S)

- Main burners do not require primary air adjustment and are not equipped with primary air shutters.
- Main burner flames form sharp blue inner cones in softer blue outer mantel, with no yellow.
- Puffs of air from blowing on flame or stamping on floor will cause flames to turn orange momentarily. This is not unusual. Remain still when observing main burner flames.
- If flame appearance is not correct, check main burner orifices, burner throat and flame ports for dust and lint obstruction. It may be necessary to remove rollout shield to observe main burner flames. Replace rollout shield after observation. Refer to Figure 16.

Figure 16 - Burner

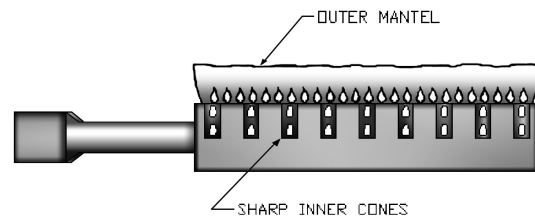

ADJUST LIMIT CONTROLS

Instructions for each control are included with controls. Settings can be changed. Refer to Appendix A page 26 for information.

CHECK THERMOSTAT OPERATION

- A. When set above temperature indicated on thermostat, boiler should ignite.
- B. Verify thermostat turns boiler off when room temperature reaches selected setting and starts boiler operating when room temperature falls a few degrees.
- C. After setting limit control to limit setting, check to see if it shuts off gas supply to burners. Turn your thermostat up to call for heat and let boiler run until temperature of water reaches limit setting. Gas valve should shut off and circulator running until thermostat is satisfied, or water cools enough to restart burners through limit control.
- D. Set thermostat for desired temperature. Conditions in your home and location of thermostat will govern this setting.

BURNERS

Beginning of heating season visually check pilot and main burner flames. See Page 16 & 17.

SAFETY RELIEF VALVE

Refer to page 7 for important information. To test safety relief valve refer to valve manufacturer's instructions packaged with relief valve. Call Technical Support if manufacturer's instruction are not located.

EXPANSION TANK

Tank may become waterlogged, or may receive excess of air. Frequent automatic opening of safety relief valve indicates water logging. High boiler temperature accompanied by unusually low radiation unit temperature (and "knocking") indicates excess air in tank.

To correct:

1. Close valve between boiler and tank. Drain tank until empty.
2. Check all tank plugs and fittings. Tighten as necessary.
3. Open valve between boiler and tank. Water will rise to normal height in tank if you have automatic fill valve (otherwise, manually refill system).

BOILER FLUE PASSAGES

Recommend following checked annually by qualified service agent.

- flue passages
- burner adjustment
- operation of controls

Before start of each season (or whenever system has been shut down for some time) recheck whole system for leaks and recheck boiler and vent pipe for leaks. Replace or patch any boiler seals that are faulty.

VENT PIPE

Venting and piping should be checked at least once a season. If vent piping shows any sign of leaking, replace immediately.

WATER SYSTEM

If system is to remain out of service during freezing weather, always **drain it** completely (water left in to freeze will crack pipes and/or boiler).

CLEANING YOUR BOILER AND BURNERS

Flue passages between sections should be examined yearly and cleaned if necessary.

To clean:

- Remove burners, pilot, and vent pipe.
- Remove top and front jacket panels.
- Remove two screws attaching intermediate front panel to left and right side jacket panels.
- Remove draft diverter and intermediate front panel together.
- Carefully remove cerafelt gasket strips.
- Clean passageways between sections with flexible handle wire brush. Remove dirt from bottom of boiler and from between sections by vacuuming.
- Verify all flame ports in burners are open and clear. Shake out or blow out all loose dirt in burners.
- Reseal seams between adjacent sections as necessary with 400° F RTV silicone sealant.
- Reassemble all parts.
- Verify tightness of pilot connections and condition of burner flames after reassembly. See Figures 15 and 16, pages 20.
- Verify vent pipe connections to chimney are secure and no obstructions are present.

HOUSEKEEPING

- Keep boiler area clear and free from combustible materials, gasoline and other flammable vapors and liquids.
- Keep boiler area clear of debris and other materials obstructing flow of combustion and ventilation air.

⚠ CAUTION

WHAT TO DO IF YOU SMELL GAS

- Do not try to light any appliance.
- Do not touch any electrical switch; do not use any phone in your building.
- Immediately call your gas supplier from a neighbor's phone. Follow the gas supplier's instructions.
- If you cannot reach your gas supplier, call the fire department.

IF YOUR SYSTEM IS NOT HEATING OR NOT GIVING ENOUGH HEAT . . .

You may avoid inconvenience and service calls by checking these points before you call for service.

Possible Cause	What to do
Thermostat is not set correctly	Reset thermostat above room temperature
Burner is not operating properly	Check flame. If it is yellow, burner is not getting enough air. Or, if flame is blue and noisy and seems to lift off burner, burner is getting too much air. Contact your service technician.
No electric power to boiler	Check over current protection. Verify electric power supply circuit is "ON".
Controls out of adjustment	Reset according to instructions.
Radiators not heating	Open radiator vents to expel air. Check flow control valve (if used). It may be in closed position.
Circulating pump not running	Check over current protection. Check relay operation.
Poor electrical contact	Check all control terminals and wire joints.
Rollout switch blown	Have your service agent check heat exchanger for blockage. Replace rollout switch with exact replacement.
Blocked vent blown	Have your service agent check venting system and chimney for blockage, or down draft condition. Reset blocked vent.
Vent damper not operating	Consult troubleshooting guide in Effikal manual, packaged with vent damper.

IF BURNER IS NOISY . . .

Possible Cause	What to do
Gas input amount is incorrect	Contact your service agent.

RELIEF VALVE LEAKING . . .

Possible Cause	What to do
Dirt on seat	Open valve manually. Allow water to run and clear valve seat.
Water logged expansion tank	Drain tank, see instructions.

HAVE YOUR SERVICE AGENT CHECK ANY PROBLEM YOU ARE UNABLE TO CORRECT.

EXPANSION TANK

Expanding water flows into expansion tank. Tank should be correct size. Tank is filled with air. As water expands it compresses air in the tank to form air pressure cushion. This "spring-like" cushion serves to maintain correct operating water pressure regardless of water temperature. This assures "full measure" of water, even in highest radiation unit of system. It also prevents blowing off of safety relief valve. Air in tank in beginning (with system filled with cold water) is sufficient for proper operation. Tank also serves as trap for excess air in system. Air would cause gurgling in pipes and in efficient circulation in radiators if left in system.

It is possible for tank to become "waterlogged" (filled with water). It can also become overfilled with air. This can happen after filling system with new water. Fittings provided on tank and in line to tank are for bleeding off excess water or air.

When installing this tank, it is important:

1. Tank be higher than boiler top.
2. Pipe to tank continuously rises up to tank (so air can "bubble" up to it).

DIAPHRAGM TYPE EXPANSION TANK

Diaphragm type expansion tank takes place of conventional expansion tank. Carefully read instructions packed with your tank assembly.

Tank comes with 10-12 pounds per square inch air charge. This is the same as pressure produced in system by automatic fill valve. When system is first filled, tank will contain little or no water.

As water is heated its pressure increases. It expands into tank, compressing air in tank. Compressed air cushion permits water in system to expand as temperature changes. Diaphragm type tank can be mounted on air purger fitting or at any convenient place in supply or return line.

AIR ELIMINATING FITTING (AIR PURGER)

Air purger is used to remove excess air from system. It is installed in supply line. It will eliminate air from water before it reaches radiators and bleed off this air.

MAIN AIR VENT FOR DOWN FLOW SYSTEMS OR DIAPHRAGM TYPE EXPANSION TANK

Before system is filled with water, there is air in pipes and radiation units. Some of it will be trapped as system is filled. It is possible to eliminate most of this air through air vent on radiation units. Main air vent will speed and simplify this. Install on highest point in supply main when all radiation is below top of boiler.

AUTOMATIC FILL VALVE

For a safe, efficient operation, hot water system must be **completely filled** with water. Adding new water, when needed can be done manually (by use of hand valve in water supply line). Requires regular attention to system's needs. Automatic fill valve accomplishes this without attention. Install in supply line on hot water boilers only. Valve operates through water pressure differentials. It does not require electrical connection.

DRAIN VALVE

Manual valve provides means of draining all water from boiler and system. It is often installed in 3/4" tapping at bottom of end boiler section. Or it can be installed in tee where return line enters boiler.

WATER TEMPERATURE CONTROL

Water temperature limit control in relay is adjustable and may be set as necessary. It may be set as low as 104°F (40°C), or as high as 220°F (104°C). This depends on type and amount of radiation involved and weather conditions.

CIRCULATING PUMP

Every forced hot-water system requires circulating pump. Separate pump or zone valve is required for each zone, if you have a two or more zone system. Pump must have capacity to provide circulation required by your system. Pump is connected into main just ahead of boiler. It is also wired to electrical system.

VENT DAMPER

This product is automatic, motorized stack damper developed to increase efficiency of heating system by reducing standby losses from heating apparatus and conditioned air space. Damper closes chimney vent when burner is off and fully opens it when combustion is required.

ROLLOUT SWITCH

(FLAME ROLLOUT SAFETY SHUTOFF)

Rollout switch is temperature-sensitive fuse link device. Located on boiler base just outside fire box. In event of heat exchanger flueway blockage causing flame to roll out of fire box, fuse does not change in appearance when blown.

If rollout switch blows, it must be replaced with exact replacement. Check heat exchanger flueways for blockage when restoring system to operating condition. DO NOT operate system without rollout switch.

BLOCKED VENT SAFETY SWITCH

(BLOCKED VENT SAFETY SHUTOFF)

Blocked vent safety switch is manual reset disc thermostat with fixed setpoint (340°F (171°C)), and normally closed contacts. It is located at relief opening of integral draft diverter. In event of chimney or venting system blockage causing products of combustion to spill out of relief opening, blocked vent disc heats up and blocked vent contacts open, shutting down flow of gas to main burners by removing power to gas valve.

In event blocked vent contacts open, reset button on back of switch will pop up. Blocked vent safety switch must be reset manually, after switch has cooled off, by pushing reset button down. Check venting system and chimney for blockage when restoring system to operating condition. DO NOT operate boiler without Blocked vent safety switch.

A.1 Installation Environment Considerations

⚠ WARNING

If you do not follow these instructions exactly, a fire or explosion may result causing property damage, personal injury or loss of life.

- **Do not use this appliance if any part has been under water.** Immediately call a qualified service technician to inspect appliance and to replace any part of control system and any gas control which has been under water.
- Do not allow water to drip on controls. Prevent condensation by allowing air circulation around module and gas control.
- Do not use corrosive chemicals around or on module or gas control.

- Controls can be damaged by excessively high temperatures. Verify adequate air circulation around control is maintained when installing boiler.

A.2 Electrical Connections

Connect Module Connectors Figure 12, Page 16

- L, N, & G leads inside J-box using wire nuts. Secure J- box cover.
- Circulator harness to circulator. Harness comes plugged into module with Molex[®] plug.
- Thermostat connection to yellow wires marked TT using wire nuts.
- Ensure remaining Molex[®] plug connectors have not worked loose during transit.
- Check sensing bulb is fully inserted in well and is not loose.
- Refer to enclosed addendum for wiring instructions when using indirect hot water heater.
- Verify vent damper connection is made. See page 13.

A.3 Adjusting Settings

To discourage unauthorized changing of settings, procedure to enter adjustment mode is required.

To enter adjustment mode, press UP, DOWN, and I buttons simultaneously for three seconds. Press and release I button until parameter requiring adjustment is displayed.

See Figure 12, page 16.

- "SP_" Setpoint (180 °F default setting; adjustable between 130 and 220 °F) Note: on some models this is "HL" High Limit.
- "Df_" Setpoint Differential (15 °F default setting; adjustable between 10 and 30 °F)
- "°F_" Degrees Fahrenheit

Press UP or DOWN button until parameter has reached desired value. After 60 seconds without any button inputs, control automatically returns to READ mode.

A.4 Display

In RUN mode, status items and parameters are viewable.

Example, to display setpoint, control flashes "sp" (setpoint) followed by temperature (i.e., 135), followed by °F or °C.

To read settings, press and release I key to find parameter of interest.

Example, press and release I until setpoint (sp) is displayed, followed by three-digit number, i.e., 190, followed by °F or °C. Press I button again will display (S1T) Sensor 1 Temperature followed by three-digit number and corresponding degree designator.

See Display Readout.

Figure 17 - Display Readout

TEXT	DESCRIPTION	DISPLAY SHOWS
STA	STATUS (SEE STATUS NUMBERS)	StA
BT	BOILER TEMPERATURE	bT
SP	OPERATING SETPOINT	SP
HL	HIGH LIMIT SETPOINT	HL
HDF	DIFFERENTIAL SETPOINT	HdF
FLA	FLAME CURRENT	FLA
RUN	RUN TIME HOURS	run
CYC	BOILER CYCLES	CYC
ERR	ERROR (SEE ERROR NUMBERS)	Err

M33683

APPENDIX A - CONTROL MODULE

A.5 Operation

Module continuously monitors boiler water temperature and fires or shuts off burner based on this temperature data.

1. When "Call for Heat" occurs, control enables circulator and monitors boiler water temperature to determine whether thermostat can be satisfied without firing burners.
2. Control determines burner operation is required,
3. Burner is de-activated, ignition module completes heating cycle, returns to idle and waits for temperature to drop again.
4. Circulator is turned on throughout "Call for Heat."

module proceeds to start burner (see state codes list) and heats water in boiler until setpoint temperature is achieved or thermostat is satisfied. .

Table 6 - Operation State Codes

State Code Number	Definition	Explanation
1	Idle or Circulator	Standby - no call for heat Heat request present. Boiler temperature sufficiently high to run circulator pump only.
4	Pre-purge	System is purging before ignition trial; includes Pilot Valve circuit diagnostics.
6	Spark	System sparking. Flame is not present up to 13 seconds
7	Flame stabilization	Flame signal is being established. Variation in signal is allowed during this state, flame must be stable at end of period
8	Running	System is running. Flame signal must be present.
9	Post-Purge	System is purging at end of call for heat
10	Retry Recycle Delay	Successful ignition was not detected, and delay is called before retry.
		Flame signal was lost during state 7 or 8, and delay is called before retry (32 second delay)
13	Soft lock-out	Soft lockout duration is one hour, may override with manual reset.
14	Hard lock-out	Manual reset is required for hard lockout
15	Wait for limit to close	Possible thermostat call for heat; limit switch is open.
16	Flame out of sequence	Flame signal sensed before trial for ignition. Appropriate alarm is sent. OR
		Flame signal sensed out of sequence during post purge. Appropriate alarm is sent. OR
		Flame signal present when not expected. Appropriate alarm is sent.
17	Pilot valve diagnostics	Pilot valve circuitry diagnostics during pre-purge.
	Current leakage detection	Self check performed at start up, again at beginning of heat cycle, and during "Wait for Recovery " State.
	Wait for recovery	Self check performed at start up, again at beginning of heat cycle, and during "Wait for Recovery " State
18	Wait for damper to open	Control has signaled damper/pressure switch to close, and is waiting for completion. If damper/pressure switch does not close within 60 seconds, control goes to State 20.
19	Wait for damper to close	Damper is closed and control waits for damper to open. Checked at beginning of heat cycle before opening damper. If damper does not open in 60 seconds, control goes to State 21.
20	Wait for damper to open (Failed close)	Damper has not opened (end switch not closed) at beginning of heat cycle. Alarm message is sent, control is NOT in lockout.
21	Wait for damper to close (Failed open)	Damper has not closed despite actuator de-energized. Alarm message is sent, control is NOT in lockout.

A.6 Boiler High Limit Temperature Controller

- When water temperature reaches setpoint, controller ends heating cycle.
- When water temperature drops below setpoint minus differential, controller restarts heat cycle to re-heat boiler water.
- If water temperature exceeds maximum allowed temperature (220°F or 104°C), controller enters manual reset lockout state.
- For models having reset capability, press any onboard button or cycle power to reset.

Figure 19 - Basic Control Algorithm Example

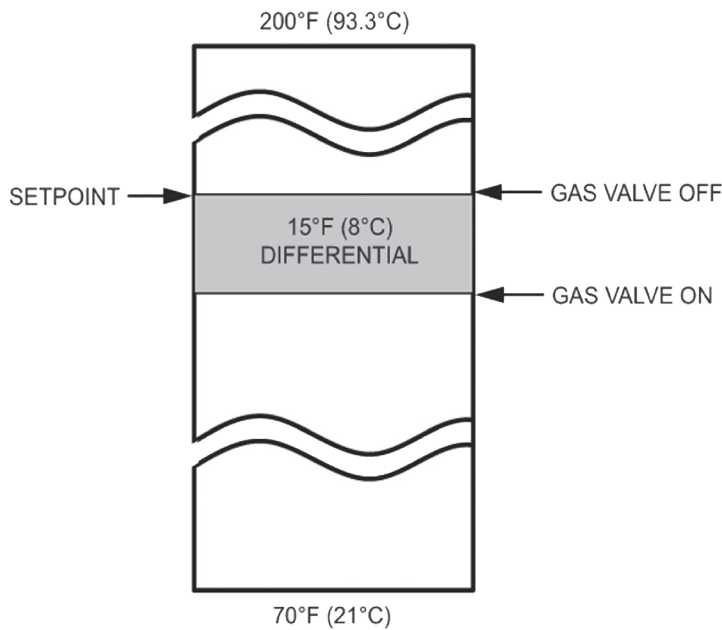

A.7 Troubleshooting

- Following service procedures are provided as general guide.
- On lockout and retry models, meter readings between gas control and ignition module must be taken within trial for ignition period. Once ignition module shuts off, lockout models must be reset through key buttons and display. On retry models, wait for retry or reset at thermostat.
- Check for correct installation and wiring before replacing any component.
- Control module cannot be repaired. If it malfunctions, it must be replaced.
- Use only qualified service agent to service ignition systems.

1. Perform checkout as first step in troubleshooting. Check troubleshooting guide to pinpoint cause of problem. See Table 7 , page 29.
2. If troubleshooting indicates ignition problem, see Ignition System Checks to isolate and correct the problem.
3. Perform checkout procedure following troubleshooting guide again to verify system is operating normally.

A.8 Troubleshooting Error Codes

Integrated boiler control uses advanced diagnostic capability to assist in troubleshooting error conditions. Table 7 page 29 shows codes that could arise on integrated display during fault. Suggestions are provided in Table 7 page 29 for servicing these potential errors.

Table 7 - Troubleshooting Error Codes

Error Code Number	Definition	Consequence
4	Flame current too low. Check for flame.	Non critical alarm
6	Flame sensed out of normal sequence (before opening or after closing gas valve).	Soft lockout
18	Gas valve relays welded. Five consecutive soft lockouts.	Hard lockout
23	Flame sensed during prepurge (before gas valve signaled opened).	Soft lockout
32	Sensor 1 error. Temperature sensor in well is not reading correctly. Verify it is connected to board. Replace if necessary.	Wait for recovery
55	Atmospheric damper end switch failed to close (end switch contacts stuck open).	Wait for recovery
56	Atmospheric damper end switch failed to open (end switch contacts stuck close).	Wait for recovery
57	Igniter flame rod shorted to burner ground	Wait for recovery
58	Igniter flame rod shorted to burner ground. Repair or replace igniter.	Wait for recovery
59	Line Voltage error - voltage out of specification high or low (15-37V (44-66Hz))	Wait for recovery
60	Applies only to thermostats having on-board transformer. Polarity is wrong in this case.	Wait for recovery
	Thermostat input higher than threshold.	
61	Line voltage unstable - possibly too may heavy loads switching on and off causing erratic supply voltage.	Wait for recovery
62	Soft lockout: maximum number of retries exceeded. (For pilot ignition)	Soft lockout
	Soft lockout is reset after one hour if alarm reason disappears.	
63	Soft lockout: maximum number of recycles exceeded. (After main burner ignition)	Soft lockout
64	Soft Lockout - electronics failure. On-board self diagnostics detected error.	Soft lockout
65	Over temperature error. Sensor measured temperature in excess of maximum allowable limit.	Hard lockout

Note: Soft lockout time is 1 hour or manual reset. Hard lockout requires manual reset.
Wait for recovery - normal operation will resume once corrected

A.9 Intermittent Pilot

Ignition System Checks

STEP 1: Check ignition cable.

- Verify ignition cable does not touch metal surfaces.
- Verify only factory supplied Ignition cable (or approved replacement) is used.
- Verify connections to ignition module and igniter or igniter-sensor are clean and tight.
- Verify ignition cable provides good electrical continuity.

STEP 2:

Verify ignition system grounding. Nuisance shutdowns are often caused poor or erratic grounding.

Common ground is required for module and pilot burner/igniter sensor.

- Check for good metal-to-metal contact between pilot burner bracket and the main burner.
- Check ground lead from GND (BURNER) terminal on module to pilot burner. Verify connections are clean and tight. If wire is damaged or deteriorated, replace with No. 14-18 gauge, moisture-resistant, thermoplastic insulated wire with 105°C [221°F] minimum rating.
- Check ceramic flame rod insulator for cracks or evidence of exposure to extreme heat, which can permit leakage to ground. Replace pilot burner/igniter sensor and provide shield if necessary.

APPENDIX A - CONTROL MODULE

- If flame rod or bracket is bent out of position, restore to correct position.

STEP 3: Check spark ignition circuit.

Disconnect ignition cable at SPARK terminal on module.

WARNING

Electrical shock hazard. Ignition circuit generates over 10,000 volts. Turn OFF electrical power supply at service panel before making electrical connections. Failure to do so could result in death or serious injury.





Energize module and listen for audible sparking noise. When operating normally, there should be buzzing noise turns on and off twice per second for duration of 1–7 seconds, depending on model.

STEP 4: Verify pilot and main burner light-off.

- Initiate call for heat. Turn thermostat above room temperature. Ignition sequence may be delayed by thermal purge until boiler water temperature is below 140°F (60°C)
- Watch pilot burner during ignition sequence.
 - Verify ignition spark continues after pilot is lit.
 - Verify pilot lights and spark stops, verify main burner does not light.
- If so, ensure adequate flame current as follows.
 - Turn off boiler at circuit breaker or fuse box.
 - Clean flame rod with emery cloth.
 - Verify electrical connections are clean and tight. Replace damaged wire..
 - Check for cracked ceramic insulator, which can cause short to ground, and replace igniter-sensor if necessary.
 - At gas valve, disconnect main valve wire from MV terminal.
 - Turn on power and set thermostat to call for heat. Pilot should light, main burner will remain off because main valve actuator is disconnected.
 - Check pilot flame. Verify it is blue, steady and envelops 3/8 to 1/2 in. [10 to 13 mm] of flame rod. See Figure 19 for possible flame problems and causes.
 - If necessary, adjust pilot flame by turning pilot adjustment screw on gas control clockwise to decrease or counterclockwise to increase pilot flame. Following adjustment, always replace pilot adjustment cover screw and tighten firmly to assure proper gas control operation. Figure 14, page 19.
 - Set temperature below room set-point to end call for heat.

- Recheck ignition sequence as follows.
 - Reconnect main valve wire.
 - Adjust thermostat above room temperature.
 - Verify ignition sequence at burner.
 - If spark does not stop after pilot lights, replace module.
 - If main burner does not light or if main burner lights and system locks out, check module, ground wire and gas control as described in troubleshooting table. See Table 6 page 27, and Table 7 page 29.

Figure 19 - Troubleshooting Pilot Flame

APPEARANCE	CAUSE
SMALL BLUE FLAME 	CHECK FOR LACK OF GAS FROM: <ul style="list-style-type: none"> • CLOGGED ORIFICE FILTER • CLOGGED PILOT FILTER • LOW GAS SUPPLY PRESSURE • PILOT ADJUSTMENT AT MINIMUM
LAZY YELLOW FLAME 	CHECK FOR LACK OF AIR FROM: <ul style="list-style-type: none"> • DIRTY ORIFICE • DIRTY LINT SCREEN, IF USED • DIRTY PRIMARY AIR OPENING, IF THERE IS ONE • PILOT ADJUSTMENT AT MINIMUM
WAVING BLUE FLAME 	CHECK FOR: <ul style="list-style-type: none"> • EXCESSIVE DRAFT AT PILOT LOCATION • RECIRCULATING PRODUCTS OF COMBUSTION
NOISY LIFTING BLOWING FLAME 	CHECK FOR: <ul style="list-style-type: none"> • HIGH GAS PRESSURE
HARD SHARP FLAME 	THIS FLAME IS CHARACTERISTIC OF MANUFACTURED GAS CHECK FOR: <ul style="list-style-type: none"> • HIGH GAS PRESSURE • ORIFICE TOO SMALL

Correct Pilot Flame: 3/8 to 1/2 inch in flame. See Figure 15, Page 20.

IMPORTANT

In accordance with Section 325 (f) (3) of the Energy Policy and Conservation Act, this boiler is equipped with a feature that saves energy by reducing the boiler water temperature as the heating load decreases. This feature is equipped with an override which is provided primarily to permit the use of an external energy management system that serves the same function.

THIS OVERRIDE MUST NOT BE USED UNLESS AT LEAST ONE OF THE FOLLOWING CONDITIONS IS TRUE:

- An external energy management system is installed that reduces the boiler water temperature as the heating load decreases.
- This boiler is not used for any space heating
- This boiler is part of a modular or multiple boiler system having a total input of 300,000 BTU/hr or greater.
- This boiler is equipped with a tankless coil.



UTICA BOILERS
2201 Dwyer Avenue
Utica NY 13501

web site: www.ecrinternational.com